

Model 5000 - Filtration Applications

Wet/Wet Differential Pressure Sensor

Define

Differential pressure measurement is the difference in pressure between two points in a system. For filtration applications, the upstream side [A] is positioned before the filter [B], whereas the downstream side [C] is after the filter. A differential pressure sensor can be used to monitor the cleanliness of a filter in either liquid or gas applications.

How It Works

1. The upstream pressure (commonly referred to as the line pressure or influent pressure) drives the media through the filter. A line is installed before the filter, as well as connected to the High side of the sensor.
2. The filter then removes contaminants from the media.
3. Next, the downstream pressure or effluent pressure, leads the media through the system with fewer contaminants than before. A line is installed on the Low side of the sensor in order to monitor the differential.
4. When the filter is free of contaminants, the system will measure 0 PSI differential in pressure. As the filter becomes clogged, the pressure on the downstream side reduces, which creates a greater differential between the High and Low sides. While using the differential pressure sensor, the unit will offer a linear output signal based on the differential pressure.

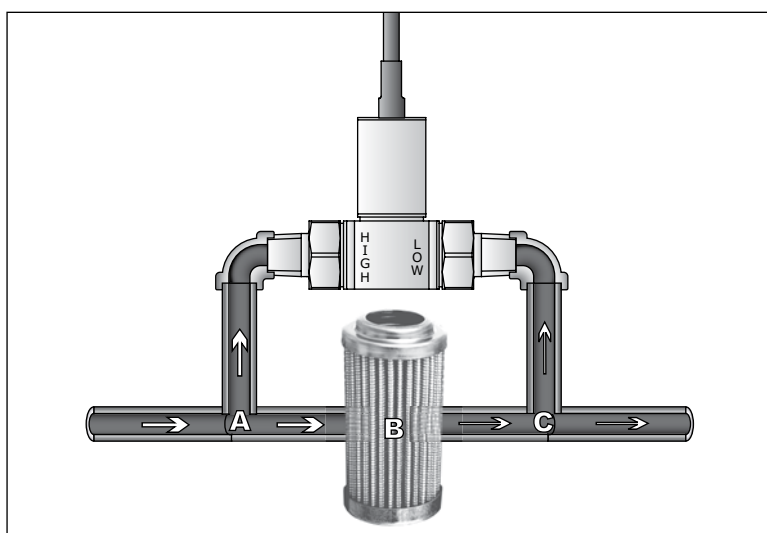

Example: Water Filtration System

A 100 PSI pump with a filter is installed to purify the water for drinking. If the downstream side in the system pressure drops to 80 PSI, the filter should be changed. With a 24VDC supply powering the sensor and a 4-20mA output signal selected, the sensor will be calibrated with a 100 PSI line pressure and 20 PSI differential pressure.

When the system is operating with a clean filter, the output signal will be 4mA. As the pressure decreases on the downstream, the output signal will increase. Once the downstream pressure has been reduced to 80 PSI, the sensor's output signal will reach the full scale of 20mA. When connected to a controller, the operator understands when to replace the filter.

Applications

- ✓ Water Filtration for Residential & Commercial Works
- ✓ Fuel Filter Condition Monitoring for Diesel Engines
- ✓ Flow Measurements
- ✓ Hydrogen Fuel Cells
- ✓ Transmissions
- ✓ Chillers
- ✓ Medical

Benefits

- ✓ Oil Free - No Oil filled cavities to contaminate the process
- ✓ Unique Single Diaphragm Design
- ✓ High Proof Pressure Rating on Both Sides
- ✓ High Strength Stainless Steel Construction
- ✓ No Internal O-Rings or Elastomers
- ✓ Compact Size
- ✓ Line and DP Pressure up to 1000PSI (70 Bar)
- ✓ mV and High Level Outputs
- ✓ Increased Resolution and Accuracy when compared with using two sensors
- ✓ Simplified Installation

Please see the Model 5000 (p.25) for complete product specifications .

