

AST4520 Class 1 Div 1, Groups C and D with Approved Barrier

Submersible Stainless Steel Media Isolated Pressure Sensor



Overview

The AST4520 Flush Submersible Series is the cost effective solution for level monitoring of turbulent tanks with viscous media. Approved to UL/cUL913 Class 1 Division 1 IS, Groups C and D with an approved barrier, the product ensures a safe, reliable source for level measurement. The AST4520 is offered with pressure ranges from 0-5 to 0-15 PSIG. The AST4520 steel cage front end design allows for proper flow of media while keeping the sensor at the bottom of the tank or well. With an engraved 316L housing and Kynar PVDF cable, this sensor is built to handle the toughest environments.

Benefits

- Engraved 316L Housing
- Protective Steel Cage Assembly
- Compatible with a Wide Range of Chemicals
- Suitable for Waste, Salt, Brackish, or Fresh Water Systems
- EMI/RFI Protection
- Reverse Polarity Protection
- Lightning and Surge Protection
- Ruggedly Designed for Harsh Waste Water Environments
- Competitively Priced for OEM Applications
- Kynar PVDF Cable
- Excellent Price to Performance Ratio

Applications

- Lift Stations
 - Wastewater
 - Storm water
 - Industrial Applications
- Food Tanks
- Viscous Media Tanks



Environmental Data

Temperature

Operating	-40 to 85°C (-40 to 185°F)
Storage	-40 to 100°C (-40 to 212°F)

Thermal Limits

Compensated Range	0 to 55°C (30 to 130°F)
TC Zero	<±1.5% of FS
TC Span	<±1.5% of FS

Other

Shock	100G, 11 msec, 1/2 sine
Vibration	10G peak, 20 to 2000 Hz.
EMI/RFI Protection	Yes
Rating	IP-68

Performance @ 25°C (77°F)

Accuracy*	< ± 0.25% BFSL
Stability (1 year)	±0.25% FS, typical
Over range Protection	2X Rated Pressure
Burst Pressure	5X or 1,250 PSI (whichever is less)
Pressure Cycles	>50 Million

* Accuracy includes non-linearity, hysteresis & non-repeatability

Electrical Data

Output	4-20mA
Excitation	10-28VDC
Output Impedance	>10k Ohms
Current Consumption	20mA, typical
Bandwidth	(-3dB): DC to 250 Hz
Output Noise	-
Zero Offset	<±1% of FS
Span Tolerance	<±2% of FS
Output Load	0-800 Ohms@10-28VDC
Reverse Polarity Protection	Yes

Ordering Information

AST4520 Y 00005 P 4 X 1 353

Series Type

Configuration Interface

Y= G1/2 with steel cage

Pressure Range

Insert 5-digit pressure range code

Pressure Unit

P = PSI

H= Inches H₂O

Outputs

4 = 4-20mA

Electrical*

X = Optional Length (see options)

Wetted Material

1 = 316L / 304 SS / Kynar

Options Cable Lengths:

353 = 25 ft. (7.62 m)

354 = 50 ft. (15.24 m)

355 = 75 ft. (22.86 m)

*Wiring information available at: <http://www.astensors.com/mediacenter.php>

Pressure Ranges

Gage PSIG	Pressure Range Code
0-15	00015
0-10	00010
0-7.5	00208*
0-5	00005

*7.5 PSI Sensor must be ordered in inches of H₂O.

Barrier Installation

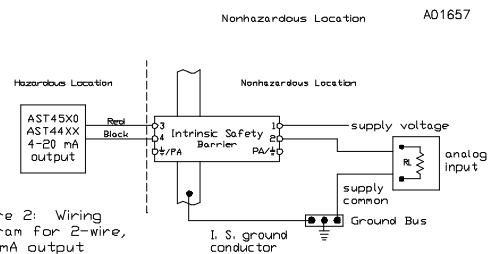
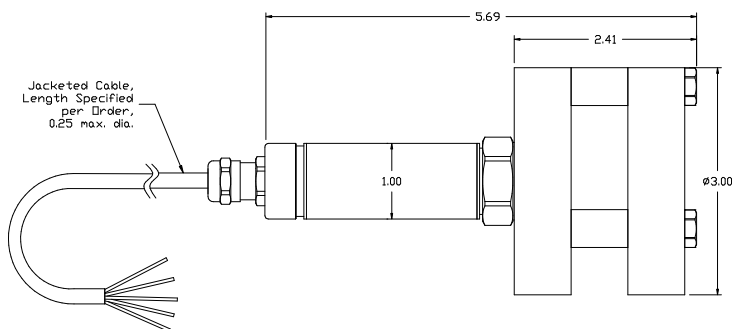

Figure 2: Wiring diagram for 2-wire, 4-20mA output

Dimensional Data



The transducers listed below are designed for installation in a Class I, Division 1, Groups C and D, Division 1 hazardous location when connected to Associated Apparatus as described in note 1.

Entity Parameters

$V_{max} = 28Vdc$

$I_{max} = 175mA$

$C_1 = 0.44\mu f$

$L_1 = 0$

I_{max} is the total current available from the Associated Apparatus under any condition.

Notes:

1. Associated Apparatus shall provide intrinsically safe connections which meet the following parameters.

$V_{oc} \text{ or } V_t \leq V_{max}$

$I_{sc} \text{ or } I_t \leq I_{max}$

$C_o \geq C_1 + C_{leads}$

$L_o \geq L_1 + L_{leads}$

2. Control Room apparatus shall not generate in excess of 250V (U_{max}).

3. Installation should be in accordance with Article 504 in the National Electrical Code, ANSI/NFPA 70.

Warranty

Workmanship - AST, Inc. pressure transmitters have a limited one-year warranty to the original purchaser. AST, Inc. will replace or repair, free of charge, any defective transmitter. All units returned for warranty evaluation must be thoroughly cleaned and free of process residue prior to shipment. Units that are not properly cleaned will be discarded and warranty service will be denied. This warranty does not apply to any units that have been modified; misused, neglected or installed where the application exceeds published ratings. AST4520 is not recommended for use with hydrogen. AST's sensors are made with pride in New Jersey, USA. If in the area please feel free to stop by for a visit!

Installation/Applications - The purchaser is responsible for media compatibility, functional adequacy, and correct installation of the transmitter.